

Explosion Proof Glands

EX 300 Metric

Nickel Plated Brass EX e & EX d dome cap glands for Non-armored cables

Metric Thread

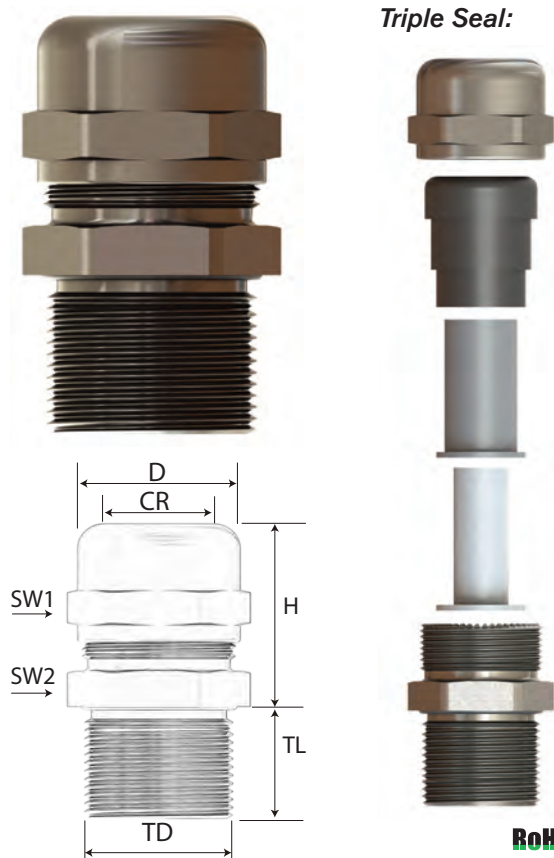

Technical data:

Material:	Nickel Plated Brass		
Seal:	Chloroprene (CR)		
Seal type:	Triple		
O-ring:	Chloroprene (CR)		
Protection type:	IP 68 5 bar (30 min)		
Temperature range:	-40°C to +80°C		
<i>Ex d/tb:</i>	-40°C to +80°C		
<i>Ex e/tb:</i>	-40°C to +80°C		
Suitable for use in:	Group II	Gas Group IIC	ZONE 1/ZONE 2
	Group III	Dust Group IIIC	ZONE 21/ZONE22
Equipment marking:	Ex II 2GD Ex db IIC Gb Ex eb IIC Gb Ex tb IIIC Db		
Marking example	BMD EBU.. CE 0722 ⚠ II 2GD Ex db IIC Gb Ex eb IIC Gb Ex tb IIIC Db Ta -40°C to +80°C IP66/68 IECEx CES 13.0006X CESI 13 ATEX 018X		

Approval	Certificate Number	Standards
ATEX	IMQ 13 ATEX 018X	EN 60079-0:2018; EN 60079-1:2014; EN 60079-7:2015; EN 60079-31:2014
IECEx	IECEx IMQ 13.0006X	IEC 60079-0:2017 Ed. 7; IEC 60079-7:2015 Ed. 5; IEC 60079-31:2013 Ed. 2; IEC 60079-1:2014 Ed. 7
UL	E474828_VOL.1_SEC.1 E199260_VOL.3_SEC.1	UL 2225 UL 514B; UL50E
TR RU	No TC RU C-TR. AA87B.00941	ГОСТ 31610.0-2014; ГОСТ IEC 60079-1:2013; ГОСТ IEC 60079-31:2013
IN METRO	DNV 21.0183 X	ABNT NBR IEC 60079-0:2013; ABNT NBR IEC 60079-7:2008; ABNT NBR IEC 60079-31:2011; ABNT NBR IEC 60079-1:2009
MARINE	TAE00003WU	IEC/EN60079-0; IEC/EN60079-7; IEC/EN60079-31; IEC/EN60079-1

Part Number	Thread Type	Clamping Range Ø min-max		Outer Diameter (D) inches	Wrenching Flats Cap Body		Thread Diameter (TD) inches mm		Thread Length EX e min. ¹ (TL) inches	Thread Length EX d/e min. (TL) inches	Max. Height (H) inches
		(CR)			(SW1)	(SW2)					
		inches	mm		inches	inches	inches	mm			
Metric											
EXMM-12	M12x1.5	0.157 - 0.315	4.0 - 8.0	0.965	0.866	0.866	0.472	12	0.354	0.630	1.299
EXMM-16	M16x1.5	0.157 - 0.472	4.0 - 12.0	0.965	0.866	0.866	0.630	16	0.354	0.630	1.299
EXMM-20	M20x1.5	0.157 - 0.472	4.0 - 12.0	0.965	0.866	0.866	0.787	20	0.354	0.630	1.142
EXMM-20C	M20x1.5	0.394 - 0.630	10.0 - 16.0	1.220	1.102	1.102	0.787	20	0.354	0.630	1.260
EXMM-25R	M25x1.5	0.157 - 0.472	4.0 - 12.0	1.220	0.866	1.102	0.984	25	0.354	0.630	1.142
EXMM-25	M25x1.5	0.394 - 0.709	10.0 - 18.0	1.220	1.102	1.102	0.984	25	0.354	0.630	1.280
EXMM-25C	M25x1.5	0.551 - 0.787	14.0 - 20.0	1.535	1.378	1.378	0.984	25	0.354	0.630	1.417
EXMM-32R	M32x1.5	0.394 - 0.709	10.0 - 18.0	1.535	1.102	1.378	1.260	32	0.354	0.630	1.280
EXMM-32	M32x1.5	0.551 - 0.945	14.0 - 24.0	1.535	1.378	1.378	1.260	32	0.354	0.630	1.378
EXMM-32C	M32x1.5	0.866 - 1.102	22.0 - 28.0	1.949	1.772	1.772	1.260	32	0.354	0.630	1.673
EXMM-40R	M40x1.5	0.551 - 0.945	14.0 - 24.0	1.949	1.378	1.772	1.575	40	0.354	0.709	1.378
EXMM-40	M40x1.5	0.866 - 1.260	22.0 - 32.0	1.949	1.772	1.772	1.575	40	0.354	0.709	1.673
EXMM-40C	M40x1.5	1.024 - 1.339	26.0 - 34.0	2.205	1.969	1.969	1.575	40	0.354	0.709	1.791
EXMM-50R	M50x1.5	0.866 - 1.260	22.0 - 32.0	2.402	1.772	2.165	1.969	50	0.354	0.709	1.673
EXMM-50	M50x1.5	1.024 - 1.378	26.0 - 35.0	2.402	1.969	2.165	1.969	50	0.354	0.709	1.791
EXMM-50C	M50x1.5	1.378 - 1.732	35.0 - 44.0	2.756	2.520	2.520	1.969	50	0.354	0.709	1.772
EXMM-63R	M63x1.5	1.024 - 1.378	26.0 - 35.0	2.953	1.969	2.677	2.480	63	0.354	0.709	1.791
EXMM-63	M63x1.5	1.378 - 1.772	35.0 - 45.0	2.953	2.520	2.677	2.480	63	0.354	0.709	1.772
EXMM-63C	M63x1.5	1.811 - 2.205	46.0 - 56.0	3.504	3.150	2.953	2.480	63	0.354	0.709	2.126

¹For 0.354 in / 9mm thread for metric glands, add -TL9 to end of P/N